

# Elevated Base Increases Mobility & Optimize Air Circulation

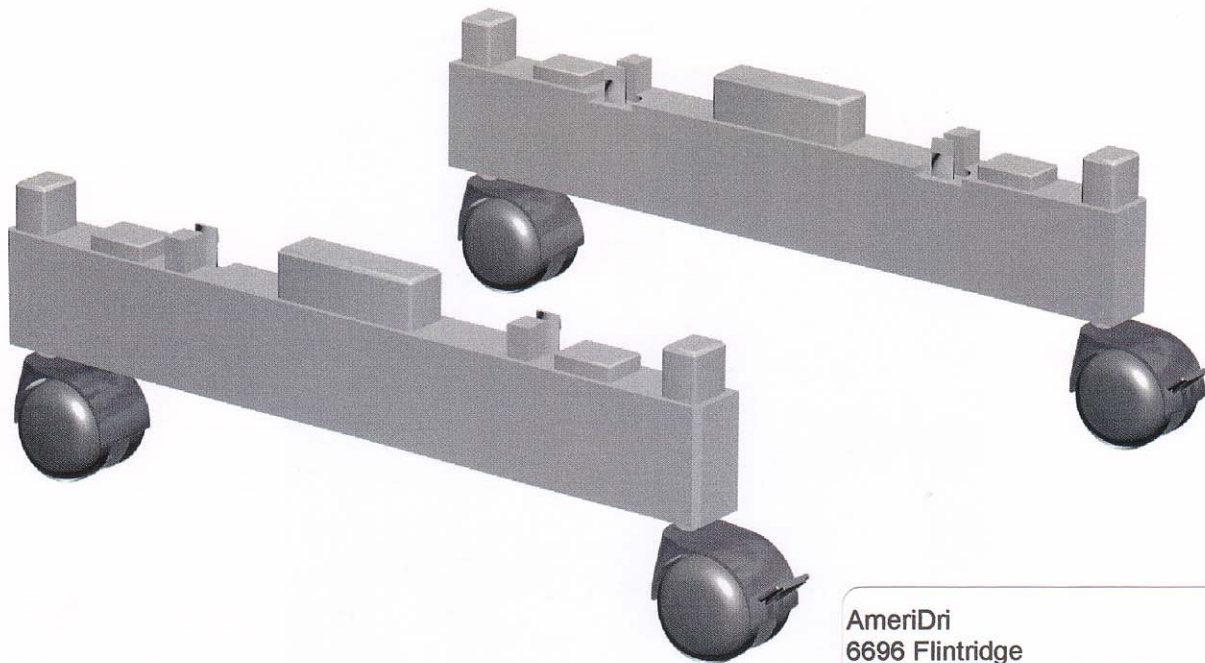

AmeriDri  
6696 Flintridge  
Colorado Springs, CO 80918  
719-388-8509  
[www.airtesters.com](http://www.airtesters.com)

The *Mobility 56* kit adds mobility to any IQAir® device. In addition, it optimizes air circulation patterns in any environment by raising the filtration unit's air intake.

No tools or assembly is required to attach the *Mobility 56* base extension kit. Simply slide the base blocks into the filtration unit's base.

Two of the four casters can lock into place to prevent unintended movement.

If mobility is not required, the casters are easily removable.

## Technical Specifications

### Base Block Material

PVC, dark grey

### Height

Adds 4.25" with casters

Adds 2" without casters

### Weight

5.5 lbs.

### IQAir® Compatibility

Compatible with all IQAir® filtration units.

Not compatible with the MaxVac™, FlexVac™ and VM FlexVac™ accessories.